



SUPREMO SERIES

USER GUIDE

SPECIFICATIONS

WOOFER

SUPREMO MW6

Nominal Impedance (Ohms)	4
Power Handling Wrms	140
Max. Trans.Pwr Handling Wrms	600
Sensitivity (2.83V/1M)	89dB
Frequency Response Hz	30-15000
Resonant Freq. Fs Hz	60
Voice Coil Diameter mm (inch)	75 (3)
Voice Coil Height mm (inch)	6 (0.23)
Voice Coil Type/ Former	Aluminum
Voice Coil Wire	Hexatech™ Aluminum
DC Resistance (Ohms)	3.5
Voice Coil Induct. @1 kHz (MH)	0.13
Magnet System	Neodymium double magnet
HE-Magnetic Gap Height mm (inch)	16 (0.64)
B-Flux Density (T.M.)	0.65
BL Product/BXL	5.19
Max. Linear Ex./Xmax mm (inch)	± 5 (± 0.02)
Suspension Compliance CMS - mm/N	0.41
Electrical Q Factor QES	0.76
QTS	0.57
QMS	2.25
Mech.Resistance RMS - Ohm/meter	2.64
Moving Mass MMS - gr	14.59
Equiv. Can Air Load VAS - L (cu.ft)	8.08 (0.28)
Effective Piston Area SD sq.cm (sq. inch)	119 (18.45)
Cone Type	One-piece formed
Cone Material	Carbon fiber/ Rohacell sandwich
Unit Diameter mm (inch)	165 (6.50)
Mounting Depth mm (inch)	61 (2.4)
Mounting Cutout mm (inch)	141 (5.55)
Net Weight Kg (lb)	1.47 (3.20)

ENCLOSURE RECOMMENDATIONS

SUPREMO MW6

Sealed Option	0.14 ft³ (4 Liter)
Sealed Range	0.11-0.35 ft³ (3.1-10 Liter)
Vented Option	0.35 ft³ (10 Liter) @ 65Hz

TWEETER

SUPERMO PICCOLO

Nominal Impedance (Ohm)	6
Power Handling (WRms)	220
Max Transient Power Handling W (10ms)	1000
Sensitivity (2.83V/1M) dB	93
Frequency Response Hz	1400-25000
FS Hz	900
Voice Coil Diameter mm (inch)	28 (1.125)
Voice Coil Former	Aluminum
Voice Coil Wire	Hexatech™ aluminum
DC Resistance Ohm	5.2
Magnet System	Neodymium flat pancake design
Dome Type	Acuflex™ hand coated soft dome
Dome Material	Silk
Unit Diameter mm (inch)	67mm (2.6)
Mounting Depth mm (inch)	32.00 (1.25)
Mounting Cutout mm (inch)	55 (2.16)
Net Weight Kg(lb)	0.35 (0.77)

CROSSOVER

MXR SUPREMO

Crossover Point	2200Hz 24dB/Oct
Crossover Controls	Tweeter +/- 2dB
Wiring Options	Bi Wire / Bi amp

INTRODUCTION

**Thank you for choosing
Morel's SUPREMO 602 component system.**

The award winning SUPREMO 602 is Morel's flagship car audio component system. Developing this product was an intensive R&D process, integrating the finest and most advanced technologies Morel developed over three decades of speaker engineering and manufacturing, with meticulous attention applied to all aspects of the design.

This craftsmanship enables the SUPREMO 602 to elevate musical presentation to whole new performance level. You will be drawn to the music; feeling the same adrenaline rush as being present at a live concert.

Morel wishes you years of musical enjoyment.

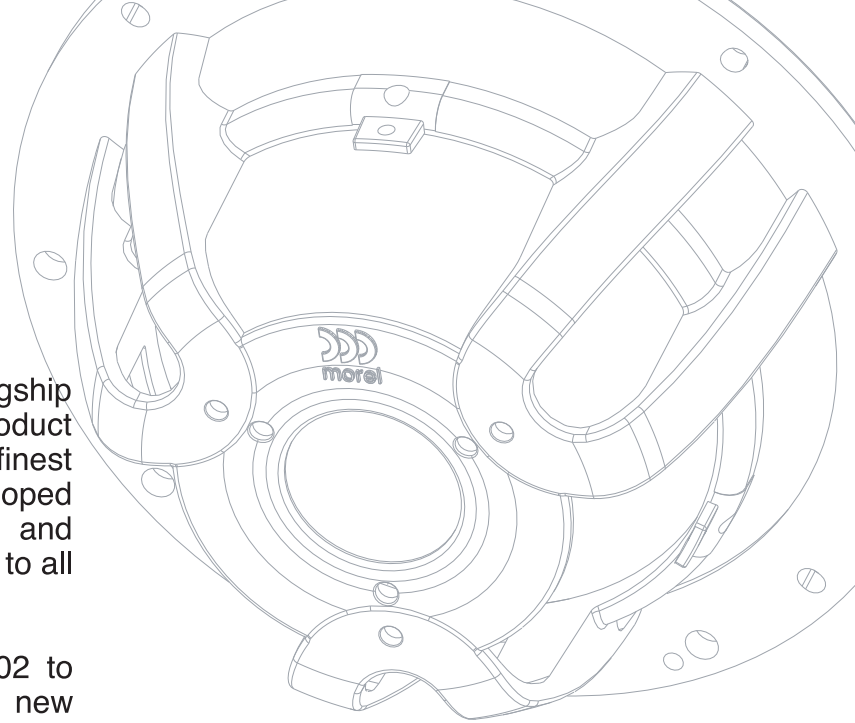

TECHNOLOGICAL FEATURES

Innovative technology and design philosophy feed the heart of Morel. The following explains some of the technology icons that have become the foundation of Morel speaker designs:

SUPREMO PICCOLO TWEETER CUT-SECTION



1. Lotus Grille

The new Morel grille has a specific pattern of holes in different shapes and diameters engineered to minimize the “horn” effect (high frequency peak caused by the resonant frequency of multiple same-size holes). Innovative metal processing enabled the construction of a very thin nearly transparent grille that hardly affects the sound at all frequencies whilst maintaining structural integrity to protect the drivers. The Lotus grille is a registered design protecting Morel’s intellectual property.

2. Under-Hung Voice Coil

An under-hung voice coil features a voice coil winding height shorter than the magnetic gap. This means the voice coil is within the magnetic energy field at all times leading to greater articulation and transient response.

3. Hexatech™ Aluminium Voice Coil

Made from 100% aluminium wire shaped like a honeycomb, the Hexatech™ voice coil reduces air gaps in the coil windings thereby increasing efficiency by up to 20%. Being lightweight, Hexatech™ voice coils are largely responsible for the extraordinary fast transient response Morel drive units are known for.

4. Acuflex™ Technology

A specially engineered damping compound applied to the soft domes of specific Morel tweeters and midranges. The combination of these materials creates a diaphragm that exhibits controlled cancelling break up (accurate-flexing), meaning each break-up mode is counteracted by another in the opposite direction. This cancellation of break-up modes leaves nothing but the pure, natural sound Morel tweeters and midrange are famous for.

5. External Voice Coil (EVC)[™] Technology

Morel speakers featuring our EVC[™] technology utilize voice coils up to three times larger than those used in conventional loudspeakers. The EVC[™] design moves the magnetic drive system to within the voice coil, eliminating stray magnetic flux by effectively directing all the magnetic energy to the voice coil. The result is an ultra efficient and powerful design, efficient heat dissipation and reduced cone breakup for lower distortion, that is highly compact.

6. Neodymium magnet motor

Morel's experience in motor design allows it to harness the magnetic energy in extremely effective manners. The most powerful magnet available, neodymium, enables Morel to create physically compact speakers, such as tweeters and midrange, that fit in very limited spaces without limiting the quality of sound.

7. Woofer carbon fibre sandwich cone

Derived from the drivers of our award winning *fat lady* speaker system, this cone design is comprised of two exterior carbon fibre skins sandwiching a layer of Rohacell—a high strength, featherweight foam. The combination forms a cone that is light, strong and properly damped for naturally uncoloured audio reproduction.

8. C.A.R. (Controlled Acoustic Resistance) Filter[™]

In most automotive applications, speakers are installed in a virtual free-air environment, such as a door, thereby providing minimal acoustic loading. The C.A.R. filter[™] improves the acoustic loading by controlling airflow within the driver, mimicking the effects of a cabinet while improving power handling by 30%. This provides greater control over the cone movement for improved bass dynamics.

9. Uniflow[™] Chassis

The Uniflow[™] chassis uses an open design that is aerodynamically efficient, allowing air and sound waves to flow uniformly and smoothly. Its geometric shape also eliminates interference with the woofer's moving components, enabling the use of a low-profile spider for greater support and stability.

10. MXR Crossover

Morel Crossover Resolution (MXR) is derived from the tour de force *fat lady* speaker system and combines several new concepts and features that improve the sound presentation and sound quality of the system.

11. Copper shorting ring

SUPREMO WOOFER CUT-SECTION

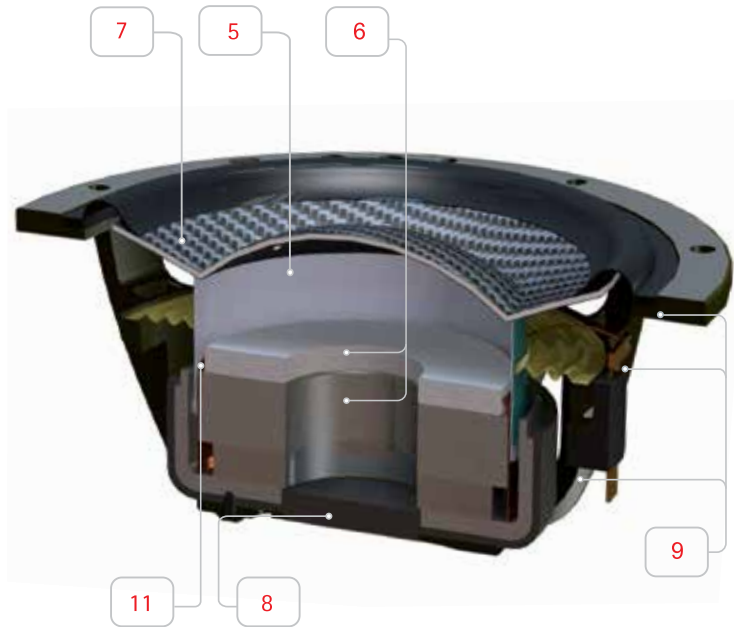

SUPREMO PICCOLO TWEETER

Seamlessly matches the Supremo woofer with an exceptionally low resonance point and flat frequency response.

All Supremo Piccolo tweeters go through stringent quality control and compatibility testing. To ensure the tweeters are perfectly matched, Morel provides a birth certificate for each pair.

Option 1 - Lotus Grille

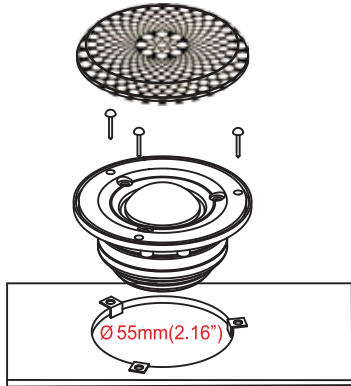

Option 2 - Mesh Grille

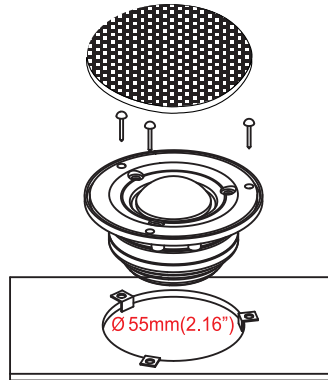

SUPREMO WOOFER

The new SUPREMO 602 woofer is an optimized version of the fat lady mid-bass driver. The new carbon fibre sandwich cone and other unique technologies are designed to reach a careful balance between the driver's Thiele-Small parameters (mainly the VAS, QTS and Fs), the car structure and the cabinet volumes in order to achieve a wider dynamic range and improved mid bass response. Delivering the transiency and transparency of Morel's home audio loudspeaker "fat lady" – to your car audio.

Option 1 - Lotus Grille

Use the black adhesive to hold the 6" Lotus grille in its cavity

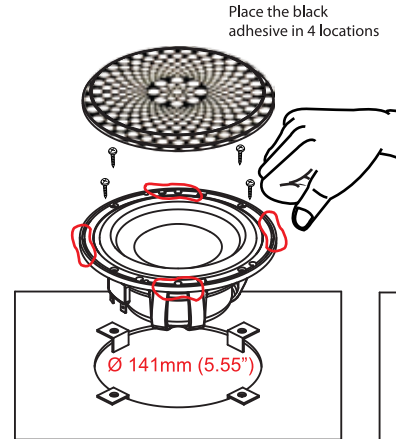

Option 2 - Octopus Grille

Not included - optional accessory

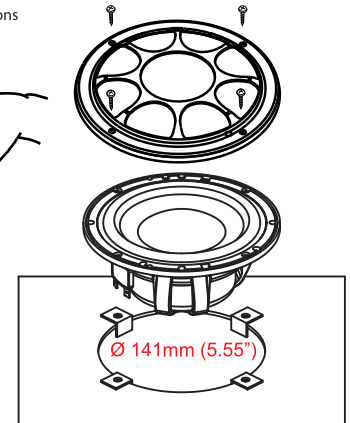

MXR SUPREMO CROSSOVER

Morel Crossover Resolution (MXR) is derived from the tour de force fat lady speaker system and combines several new concepts and features that, improve the sound presentation and sound quality of our systems.

Engineered to meet the most challenging acoustic conditions of a car, it employs Mundorf components, positive phase, sharp roll-off, and resistor-free signal paths to create total sound integration between the Supremo components to recreate a realistic three-dimensional sound.

MXR SUPREMO CROSSOVER WIRING OPTIONS

**1 Standard Wire connection/
With bridged jumpers**

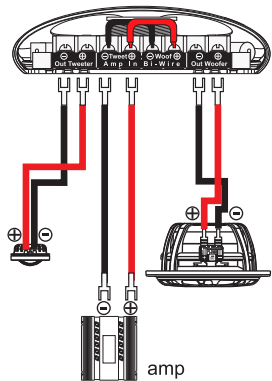

**2 Bi Wire connection/
No bridged jumpers**

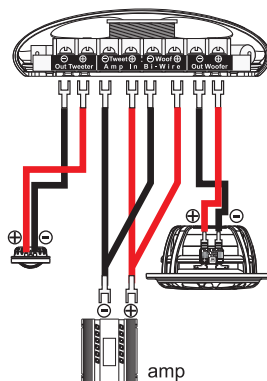

**3 Bi Amp connection/
No bridged jumpers**

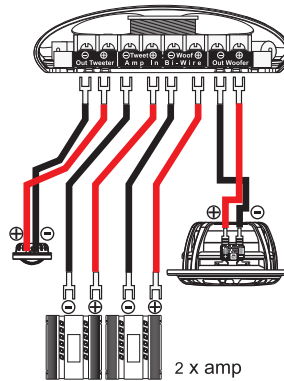

TWEETER ATTENUATION LEVEL

The Supremo crossover offers a flexible tweeter attenuation level for improved soundstage and imaging

Use the jumper to determine the tweeter +/- dB level

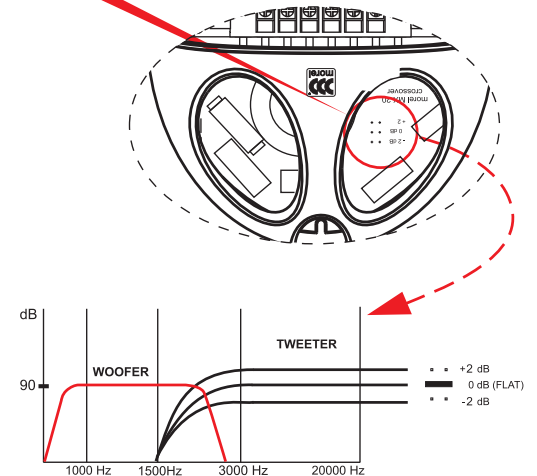

UNLEASH THE MUSIC



w w w . m o r e l h i f i . c o m